

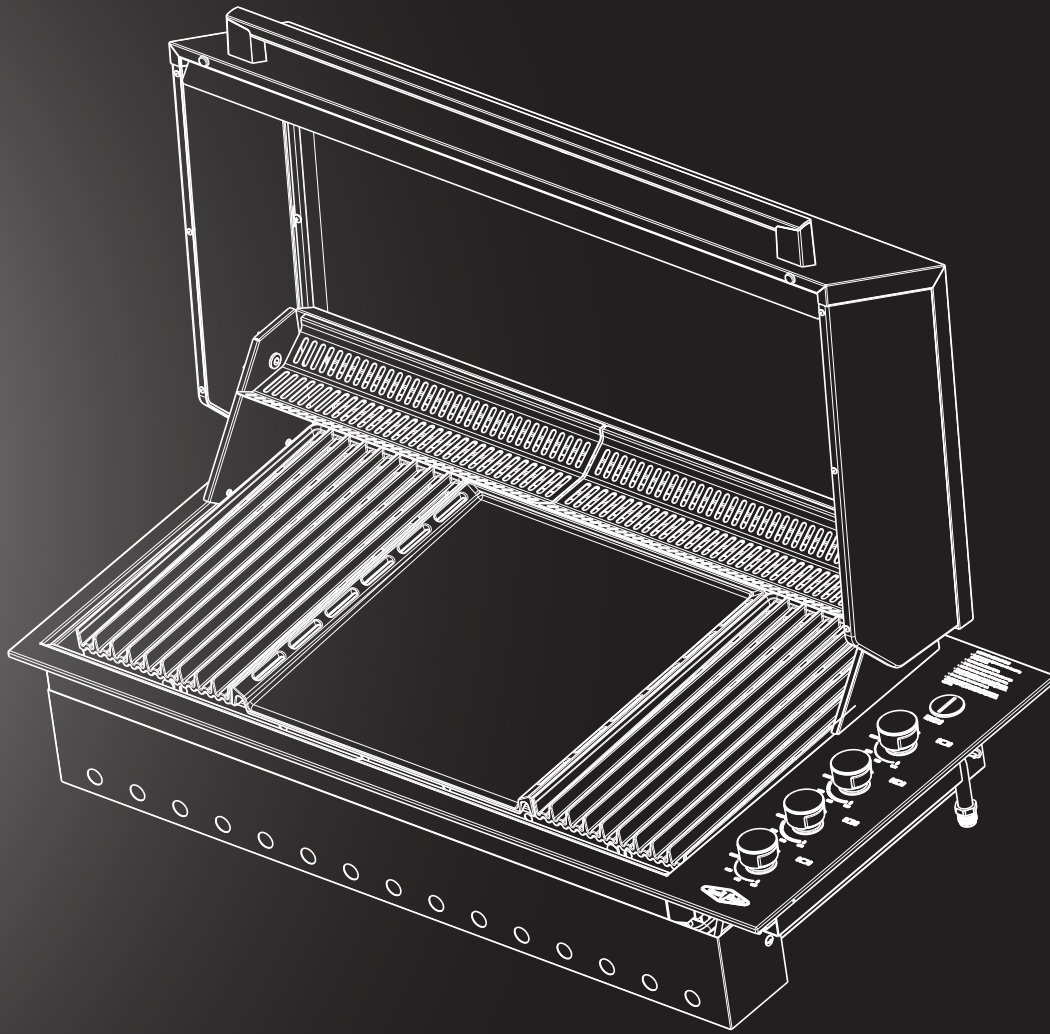

Assembly and Operating Instructions

# INTEGRATED SERIES

BSH158SAEU, BSL158SAEU



Dear customer,

Congratulations and thank you for choosing our barbecue. We are sure you will find it a pleasure to use. Before you use the barbecue, we recommend that you read through the relevant sections of this manual, which provide a description of your appliance and its functions.

To avoid the risks that are always present when you use an appliance, it is important that the appliance is installed correctly and that you read the safety instructions carefully to avoid misuse and hazards.

We recommend that you keep this instruction booklet for future reference and pass it on to any future owners.

After unpacking the appliance, please check it is not damaged. If in doubt, do not use the appliance but contact your local customer care centre.

This appliance complies with requirements of BS EN 498:2012.

## CONDITIONS OF USE

**These important notes apply to your appliance, failure to adhere to these conditions of use may affect your ability to make a claim under the manufacture's warranty.**

- This appliance **MUST** be serviced only by a qualified licensed person.
- This product is intended for personal, domestic or household use only, not commercial use.
- This appliance is designed to be used outdoors and well ventilated indoor areas.
- This product must be installed, operated and maintained as per the instructions.
- Ventilation holes in the unit must not be obscured by the installation.

**Please ensure you read the instruction manual fully before you call for service, or a full service fee could be applicable.**

Record model and serial number here:

Model number: .....

Serial number:.....

PNC:.....

Important safety instructions.....	3
Product description.....	4
Parts.....	5
Gas specifications.....	6
Leak test procedure .....	7
Gas conversion instructions.....	8
LPG safety information.....	9
Installation warnings.....	10
Dimensions.....	12
Gas requirements.....	14
Assembling the barbecue .....	14
Hotplate configuration .....	15
Operating instructions .....	16
Lid safety lid – slimline lid only.....	17
Cleaning and care.....	17
Maintenance .....	19
Troubleshooting.....	20
Accessories.....	20
Notes.....	21
Warranty .....	23

Please read instruction manual carefully before using the appliance and store in a handy place for later reference.

The symbols you will see in this booklet have these meanings:



**WARNING**

This symbol indicates information concerning your personal safety.



**CAUTION**

This symbol indicates information on how to avoid damaging the appliance.



**IMPORTANT**

This symbol indicates tips and information about use of the appliance.



**ENVIRONMENT**

This symbol indicates tips and information about economical and ecological use of the appliance.

# IMPORTANT SAFETY INSTRUCTIONS

Please read the user manual carefully and store in a handy place for later reference.



## IMPORTANT

Important – check for any damages or marks.

If you find the barbecue is damaged or marked, you must report it within 7 days if you wish to claim for damage/marks under the manufacturer's warranty. This does not affect your statutory rights.



## ENVIRONMENT

Information on disposal for users

- Most of the packing materials are recyclable. Please dispose of those materials through your local recycling depot or by placing them in appropriate collection containers.
- If you wish to discard this product, please contact your local authorities and ask for the correct method of disposal.



## WARNING

This appliance must be serviced only by a qualified licensed person.

Improper installation, adjustment, alteration or maintenance can cause injury or property damage and may affect your ability to claim under the manufacturer's warranty.

Please contact your local Beefeater Distributor for additional information or assistance for an approved installer.

NOTE: This manual must remain with the owner for future reference.



## IMPORTANT

This appliance is fitted with flame supervision devices, also known as flame failure

### Operating Instructions

For added gas safety, your barbecue is fitted with Flame Failure Technology. This safety system will shut off the gas supply to an individual burners if the flame goes out for any reason.

### How It Works

Flame Failure Technology switches gas off to an individual burner if the flame goes out. During normal operation the burner flame is in contact with the sensor probe. If the flame is blown out by a strong breeze for example, the control valve will shut off the gas supply to the burner to avoid a continuous gas leak.



## WARNING

- Accessible parts may be very hot. Keep young children away.
- Read instructions before using the appliance
- Do not move the appliance during use
- Turn off the gas supply at the cylinder after use.
- Use protective gloves when handling particularly hot components.
- Do not lean over barbecue when lighting.
- Do not leave the barbecue unattended when alight.
- Do not delay lighting once the gas has been turned on.
- Do not place articles on or against this appliance
- Do not spray aerosols in vicinity of this appliance while it is in operation.
- Do not use or store flammable materials in or near this appliance.
- Do not use caustic or abrasive based cleaners on the barbecue.
- Do not attempt to dismantle or adjust the control valves.
- Do not attempt to dismantle or adjust the regulator.
- Do not test for leaks with a naked flame.
- Do not modify this appliance.
- Do not obstruct any ventilation of the barbecue.
- Parts sealed by the manufacturer or his agent shall not be manipulated by the user.
- Check whether the venturis of burners are blocked before using the appliance.

Failure to adhere to the above warnings may cause injury or property damage and affect your ability to make a claim under the manufacturer's warranty.



## CAUTION

This appliance is set up for LPG and is labelled accordingly. Conversion of this unit to alternate gas types is possible however must be carried out by a qualified licensed person and a Certificate of Compliance must be issued to the owner at the completion of the installation and conversion.

# PRODUCT DESCRIPTION

## Integrated barbecue with slimline lid BSL158SAEU

- ① Pivoting leg
- ② Slimline lid
- ③ Battery cover
- ④ Gas connection point
- ⑤ Burner controls
- ⑥ Cast Iron Grill
- ⑦ Cast Iron Hotplate
- ⑧ Removable oil reservoir located at front of cooking surface (not illustrated)
- ⑨ Flame tamers x 2 located under grills (not illustrated)

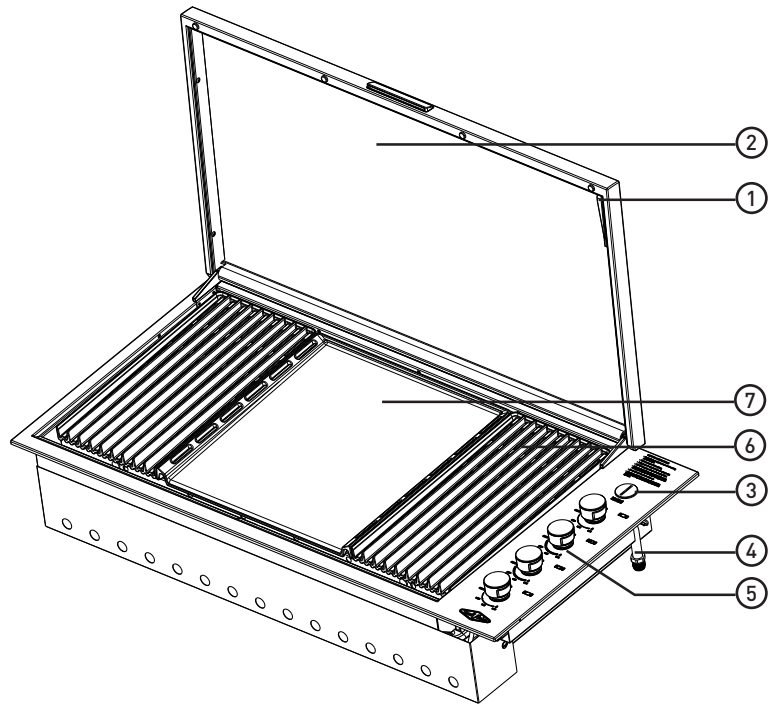

## Integrated barbecue with roasting hood BSH158SAEU

- ⑩ Roasting hood
- ⑪ Warming racks
- ⑫ Battery cover
- ⑬ Gas connection point
- ⑭ Burner controls
- ⑮ Cast Iron Grill
- ⑯ Cast Iron Hotplate
- ⑰ Removable oil reservoir located at front of cooking surface (not illustrated)
- ⑱ Flame tamers x 2 located under grills (not illustrated)

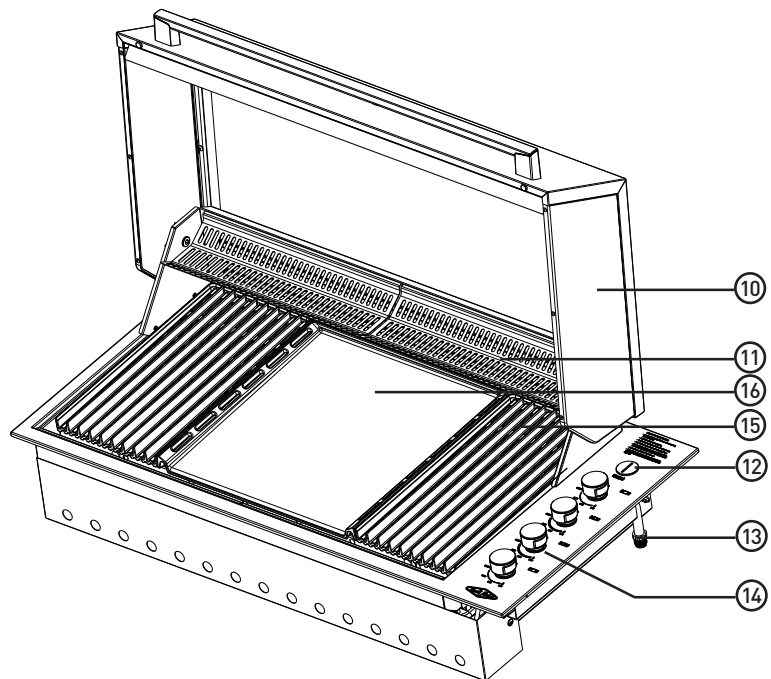

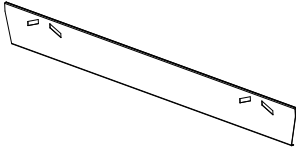
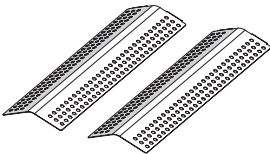
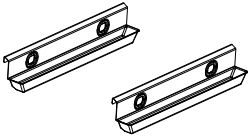
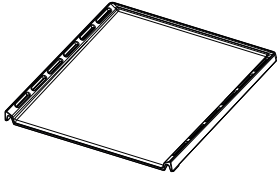
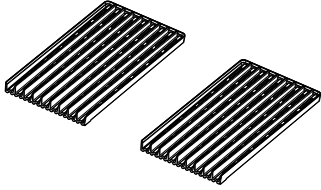
	DESCRIPTION	QTY
	Rear heat shield	1
	Flame tamers	2
	Oil reservoirs	2
	Cast Iron plate	1
	Cast iron grill	2

DESCRIPTION	QTY
1 Plastic bag, containing this instruction book, labels, 1 fibre washer, brass adaptor, nut and tail fitting, gas injectors for conversion to alternate gas	

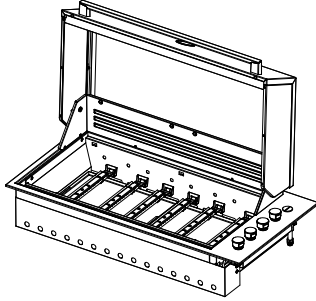
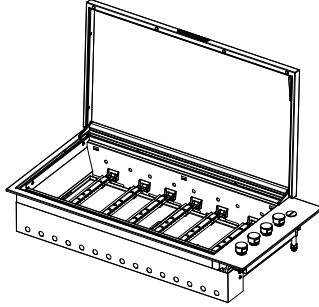
EITHER	DESCRIPTION	QTY
	Roasting hood and base assembly	1
	Slimline lid and base assembly	1

# GAS SPECIFICATIONS

COUNTRY	BE, FR, IT, LU, IE, GB, GR, PT, ES, CY, CZ, LT, SK, CH, SI, LV	LU, NL, DK, FI, SE, CY, CZ, EE, LT, MT, SK, SI, BG, IS, NO, TR, HR, RO, IT, HU, LV	PL	AT, DE, SK, CH, LU	FR, IT, DK, IE, GB, GR, ES, PT, AT, FI, SE, CZ, EE, HU, LV, LT, SK, SI, IS, NO, CH, TR, HR, RO	DE, LU, PL, NL
CATEGORY	I3+(28-30/37)	I3B/P (30)	I3B/P (37)	I3B/P (50)	I2H	I2E
TYPE	Butane Propane	BUTANE, PROPANE OR THEIR MIXTURES			NATURAL GAS	
GAS INLET PRESSURE (MBAR)	28-30	37	28-30	37	50	20
INJECTOR Ø (MM)		0.90		0.85	0.78*	1.30
TOTAL HEAT INPUT	18.6 kW (1354 g/h for LPG)				17.2kW	

\*When installed with a second stage regulator reducing pressure to 28-30mbar there is no requirement to change the factory fitted injectors.

## NOTES:

- This appliance MUST be serviced only by a qualified licensed person.
- This appliance is designed to be used outdoors and well ventilated indoor areas.
- This product must be installed as per the instructions which requires the installation of venting to enable the barbecue to operate correctly. Failure to provide adequate ventilation for supply of air to the appliance may result in poor burner performance or excessive heat build-up within the mounting enclosure.
- Ventilation holes in the unit must not be obscured by the installation.

Failure to adhere to these installation instructions may affect your ability to make a claim under the manufacturer's warranty.

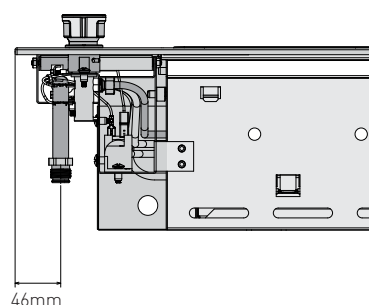
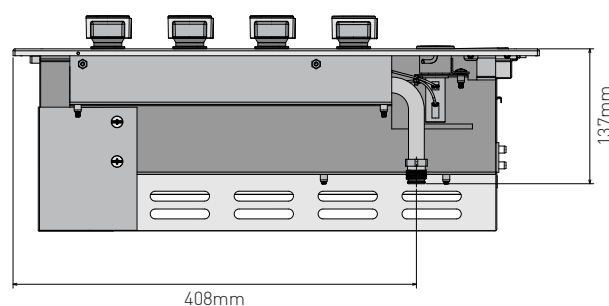

## LP/Propane Installation

This barbecue is set up for LPG gas and is labelled accordingly. Gas conversion kits and fitting procedures vary in some markets. For details of the kit and fitting instructions appropriate for your market, please contact your local BeefEater distributor..

### Connecting the appliance to an LPG/Propane gas supply

1. Fit the brass adaptor to the gas inlet pipe ensuring the blue fibre washer is in place. Do not over-tighten.
2. Attach nut and tail fitting to the 3/8" SAE connector. Do not over-tighten.
3. Attach appropriate hose and regulator assembly and secure with hose clamp.
4. Once connections are made, the leak test should be conducted.

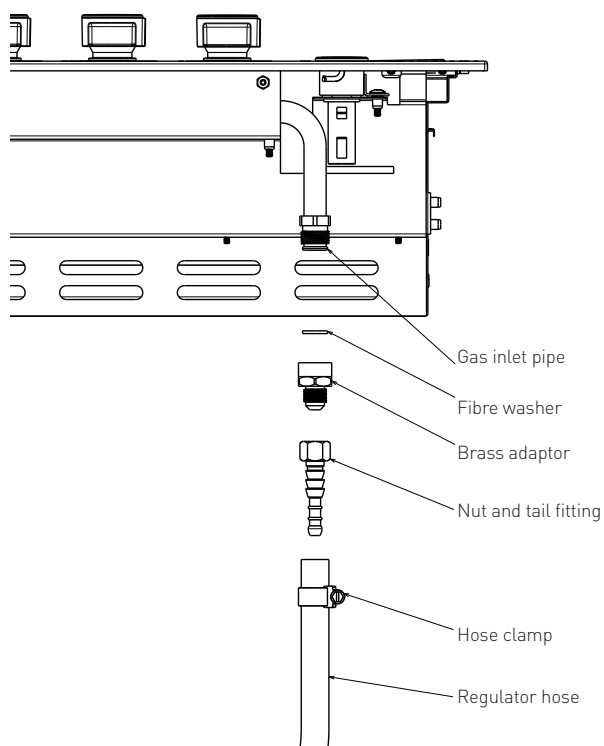

## Leak test procedure

- Ensure all gas valves are in the 'OFF' position.
- In a small container, mix a solution of water and detergent or soap.
- After connection of the hose, turn on the gas supply at the gas bottle or mains as appropriate.
- Using a brush apply the solution to the gas connection points and look for bubbles forming.
- Bubbling will indicate a leak.
- Turn off the gas supply and re-tighten the joint. Repeat the leak test.
- If the leak persists, turn off the gas at the isolation valves and contact a licensed gas fitter to correct.

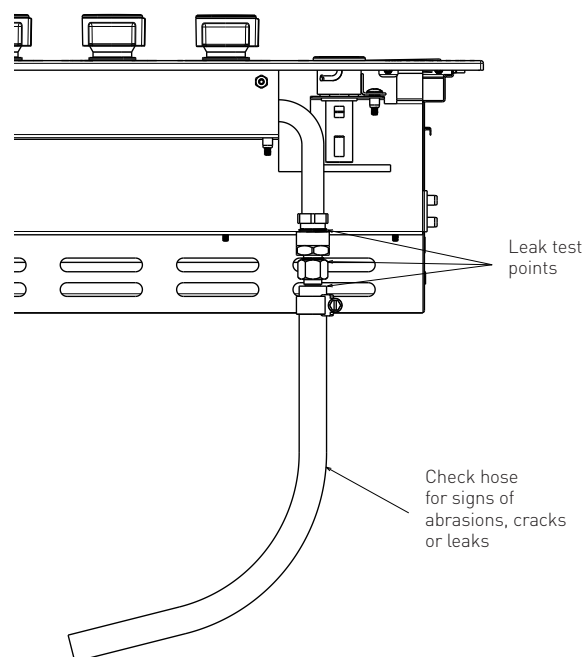

# GAS CONVERSION INSTRUCTIONS

NOTE: Conversion of this unit to alternate gas must be carried out by a qualified licensed person and a Certificate of Compliance must be issued to the owner on completion of the installation and conversion. Conversion of this barbecue by unlicensed persons may result in improper functioning of the appliance, injury, property damage and may affect your ability to make a claim under the manufacturer's warranty.

## Converting the unit to alternate gas

Gas conversion kits and fitting procedures vary in some markets. For details of the kit and fitting instructions appropriate for your market, please contact your local BeefEater distributor.

### Procedure

#### 1. Change the injectors

- To convert to alternate gas it may be necessary to change the injector size (refer to Gas Specification Table on page 6). To change the injectors, first remove the spark electrode and thermocouple from each burner as required.

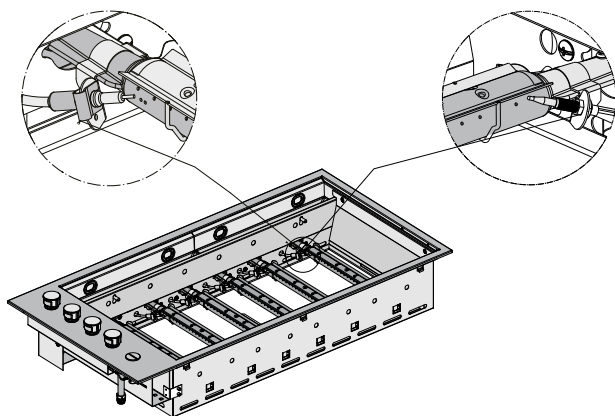

- Release the burner from the retaining bracket by lifting as shown.

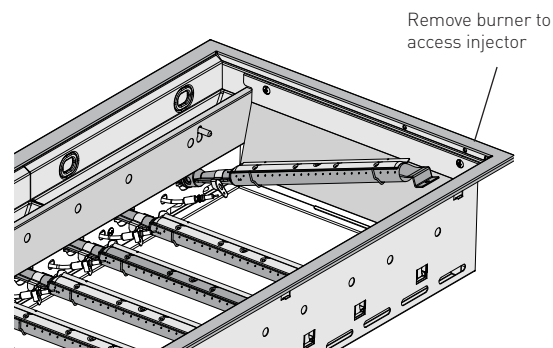

- Replace the injector with appropriate size injector (refer to Gas Specification Table on page 6). All injectors are marked with the orifice size.

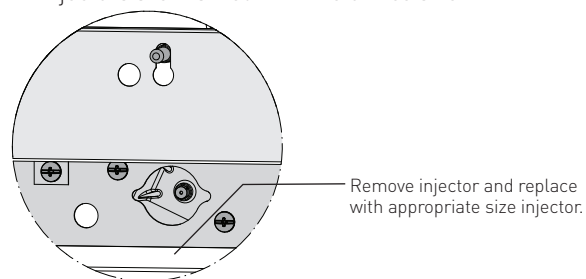

- Install burner and replace the spark electrode and thermocouples.
- Repeat for the other 5 burners

When changing gas types it may be necessary to adjust the valve to achieve the desired turn down setting. This can only be completed after the connection to the gas supply and leak test has been conducted.

#### 2. Adjust the turndown setting on the valve

- Light each burner and rotate the control knob to the lowest setting, then remove the knob from the valve shaft, and remove the grommet.
- Using a small flat-blade screwdriver adjust the turndown adjustment screw to achieve a small steady flame on the burner.

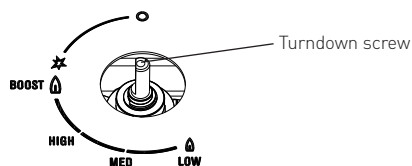

- Replace the grommet and the knob
- Recheck the operation of the burner at maximum and turndown
- Repeat procedures for all valves.



## LPG safety information

- Use only gas cylinders, which meet national and regional codes. The minimum cylinder size for this barbecue is 6kg. Ensure that the cylinder can provide enough fuel to operate the appliance. If in doubt, check with your local gas supplier.
- Pay attention that when changing the gas cylinder which shall be carried out away from any source of ignition.
- Never connect a cylinder, which does not meet local codes.
- All cylinders 7kg or larger must be placed on the ground at the rear of the barbecue. Cylinders smaller than 7kg (maximum size 465mm high by 306mm wide) may be placed on the hook at the rear (as shown). Cylinders must not be exposed to extreme heat or direct sunlight.
- The isolation valve must be turned off when the appliance is not in use.
- Gas cylinders must be stored in an approved housing out of reach of children.
- When disconnecting the gas bottle ensure that all the control valves are in the 'OFF' position.
- When reconnecting the hose to the bottle, ensure that all connections are tight before replacing in storage compartment.
- Carry out a leakage check as detailed below after each reconnection.
- Only regulator which complies with EN 16129 can be used.
- The length of hose cannot exceed 1.5m. In Finland, the length of hose cannot exceed 1.2m.
- It's necessary to change the flexible tube when the national conditions require it, and/or depending on its validity.
- Make sure that the flexible tube is not subjected to twisting when the appliance is in operation.

## INSTALLATION WARNINGS



### WARNING

- This appliance shall only be used in an above ground, open air situation with natural ventilation without stagnant areas, where gas leakage and products of combustion are rapidly dispersed by wind or natural convection. This appliance is designed to be used outdoors and well ventilated indoor areas. Failure to adhere to these installation instructions may cause injury or property damage and affect your ability to make a claim under the manufacturer's warranty. Refer to diagrams below.
- Never install this barbecue inside any building, garage, shed or breezeway or inside a boat, caravan or recreational vehicle. This is to prevent the possibility of fire or carbon monoxide poisoning or asphyxiation.
- Any enclosure in which this appliance is installed shall comply with one of the following:
  - An enclosure with walls on all sides, but at least one permanent opening at the ground level and no overhead covering
  - Within a partial enclosure that includes an overhead cover and no more than 2 walls
  - Within a partial enclosure that includes an overhead cover and more than 2 walls, the following shall apply:
    - at least 25% of the total wall area is completely open and at least 30% of the remaining wall area is open and unrestricted
- In the case of balconies, at least 20% of the total of the side, back and front wall areas shall be and remain open and unrestricted.

## Choosing a location

When planning the location and preparing the installation structure for this appliance note the following:

- This appliance must be installed in accordance with local authority.
- Requirements in these instructions for clearances to combustible materials also apply to combustible materials that have non-combustible materials attached to their surface.
- This appliance must be installed such that no part of the appliance is in contact with or within 10mm of any combustible material.
- The minimum clearance to a vertical wall or splashback above bench level and behind the barbecue that is made from combustible material is 450mm for a model with a roasting hood and 250mm for a slimline lid model.
- The vertical clearance above the cooking surface to any combustible materials must be at least 1000mm.
- The minimum clearance to a vertical wall above the bench level made from a combustible material is 250mm on the left and right hand side.
- When using LPG in an enclosure ventilation must be provided. Gas is highly explosive and can cause serious injury and damage to property if allowed to accumulate and then be ignited.
- This barbecue is intended to be built into a benchtop with a minimum depth (front to rear) of 600 mm.
- Avoid windy positions as this will affect cooking performance and burner efficiency. If this situation cannot be avoided some shielding may be necessary.

## The mounting enclosure

- The barbecue requires a non-combustible barrier under the barbecue to prevent excessive temperatures being accessed. The barrier panel is to be placed at least 30mm under the base of unit.
- The benchtop that supports the barbecue must be constructed from non-combustible material. Suitable materials include masonry, granite, marble, Hardiplank®, Villaboard® over a metal frame, or tiles on a non-combustible substrate.
- This appliance requires venting. The vent opening can be in either of two alternative locations – Front wall below the bench, or the non-combustible barrier under the barbecue. Refer to diagrams (on next page) for vent specification and location alternatives.
- This appliance can be mounted either in an island type bench or a bench with a splashback. Please read the specific requirements for each mounting situation.
- For LP / Propane use, cabinetry below the barbecue must have low level venting to prevent the possibility of LPG accumulating.
- Clearances to parts of the supporting structure must be in accordance with the following diagrams:

# DIMENSIONS

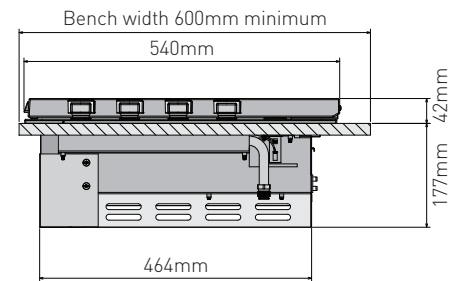
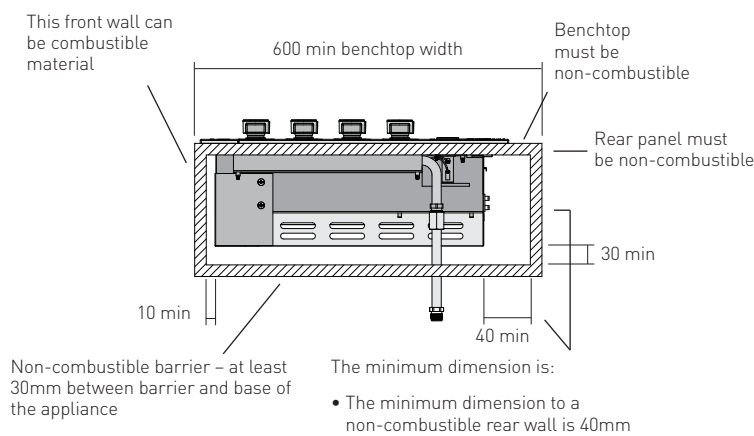
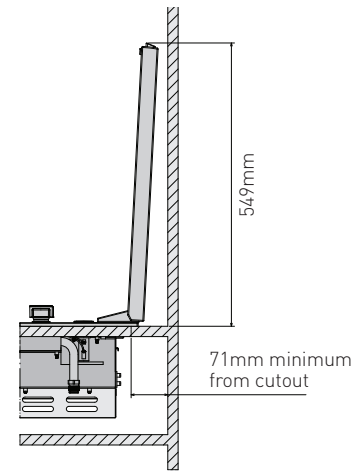
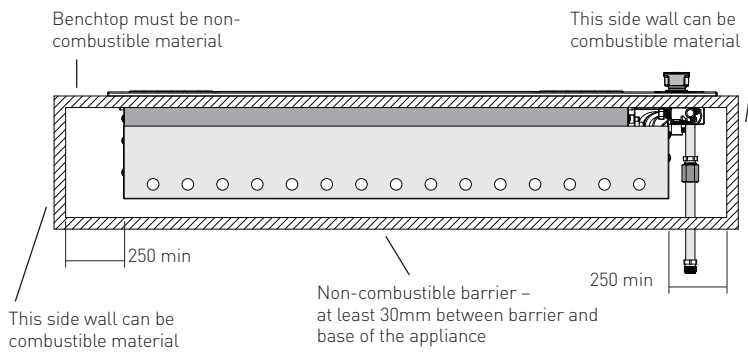

## Island style installation

(example shown with barbecue with slimline line)

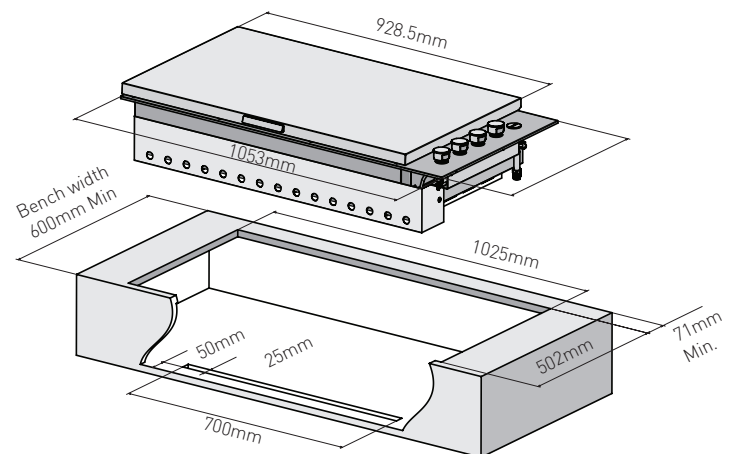

Alternate vent location in base of enclosure  
(front panel cut away for clarity)

## WARNING!

This appliance requires venting. An open area as indicated must be allowed for. A suitable grille can be fitted if desired. This vent area is to allow air into the enclosure for the correct combustion of gases and for the correct exhausting of the products of combustion. The vent must be no less than 700mm x 25mm.

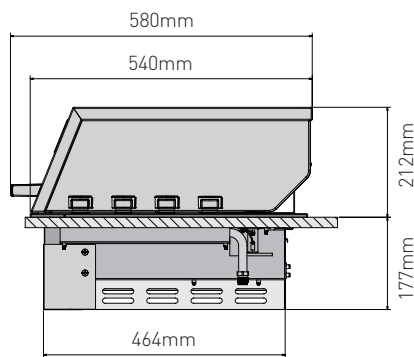
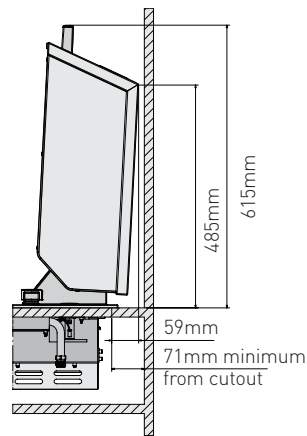

### Installation in a bench with splashback

(example shown with barbecue with roasting hood)

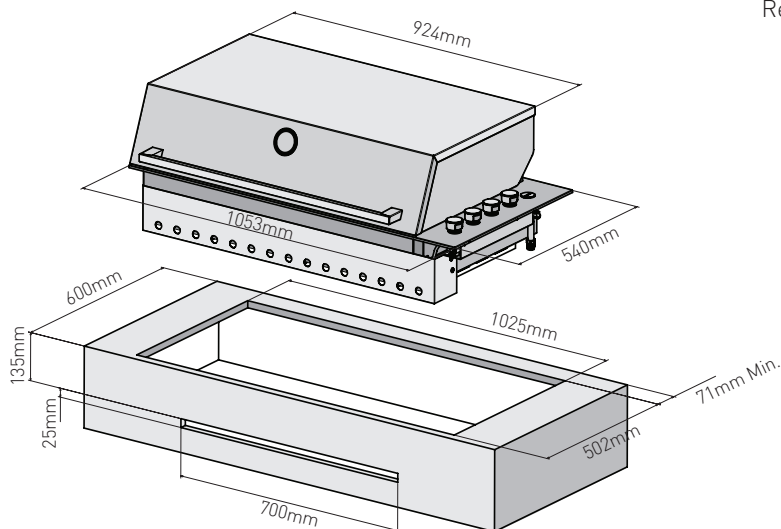

### **WARNING!**

This appliance requires venting. An open area as indicated must be allowed for. A suitable grille can be fitted if desired. This vent area is to allow air into the enclosure for the correct combustion of gases and for the correct exhausting of the products of combustion. The vent must be no less than 700mm x 25mm.

### Installing in a bench with a splashback

- The splashback must be made from a non-combustible material unless it is at least 450mm from the appliance.
- Clearances between the barbecue and a combustible splashback are 250mm for the slimline lid model and 450mm for the roasting hood model.
- The minimum depth (front to rear) of the mounting bench is 600mm.
- The bench cut-out size required is 1025mm x 502mm. Refer to diagram above to left.
- For roasting hood models there is a specific clearance required at the back of the barbecue between the splashback and the bench cut-out of 71mm minimum. This is to allow clearance for the hood to open.

### Island style installation

- If this appliance is installed in an island mount, it can be centrally positioned, provided all other instructions regarding clearances to combustible materials are followed. Special attention should be given to the overall size of the island top to consider the hood open and the overhang. Please see illustration.
- The cut-out size required is 1025mm x 502mm. Refer to diagram.

### **WARNING!**

- If an LPG bottle is to be stored in the enclosure under the barbecue unit, it must be isolated from the barbecue unit with a non-combustible panel.
- Ventilation requirements for cylinder storage are:  
Where of sheet metal or similar impervious construction there shall be ventilation openings at the top and bottom of the enclosure or recess, each opening providing a free area of at least 200cm<sup>2</sup> for every cylinder enclosed.
- For LP / Propane installations having enclosed cabinetry below the separation panel that does not contain a gas bottle, low level venting must be installed. This is to allow the gas which is heavier than air to escape from the enclosure in the situation where there may be a leak. A minimum opening of 200cm<sup>2</sup> is required.

### Setting up the barbecue

#### Setting up the barbecue in mounting enclosure

- A match holder with attached chain has been included with the instruction manual. This is provided for manual ignition in the event the automatic ignition does not work. The free end of chain is required to be permanently fixed to the installation in a location that enables the match holder to reach each burner (refer to page 16 for manual lighting instructions).

1. Remove all components from box.
2. Attach heat shield to rear of unit by inserting the three top tabs into the rear holes and sliding the shield down.

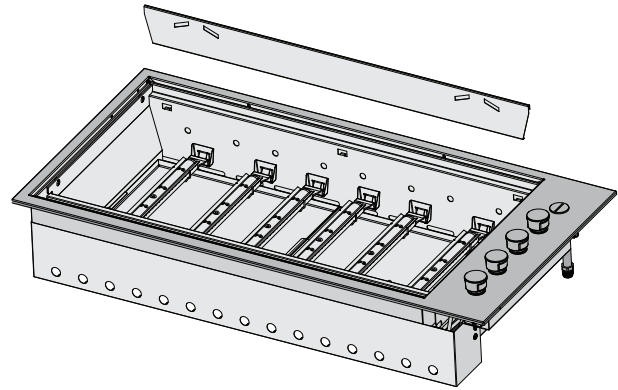

3. Install flame tamers (under grills) and fix back edge of flame tamer into the heat shield panel.

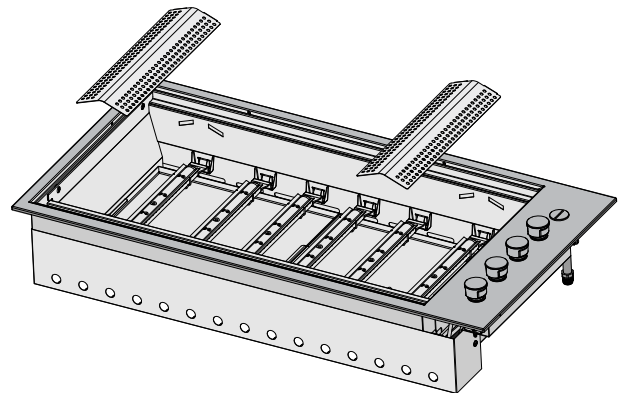

4. Fit oil reservoirs at front of barbecue.

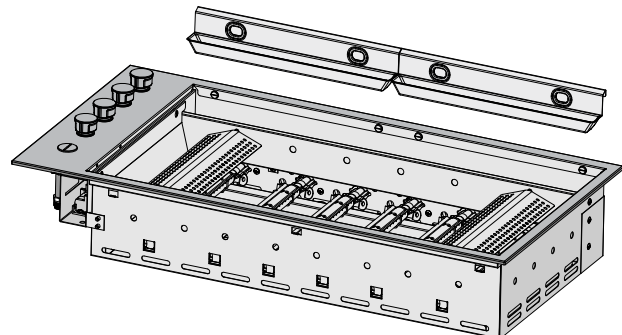

**5. Install hotplates and grills as shown, ensuring that the flame tamers are located under the grills.**

NOTE: ensure that grill assemblies are orientated correctly so that the surface of the grill is sloping forward to allow oil to drain into oil reservoirs.

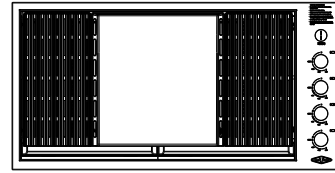
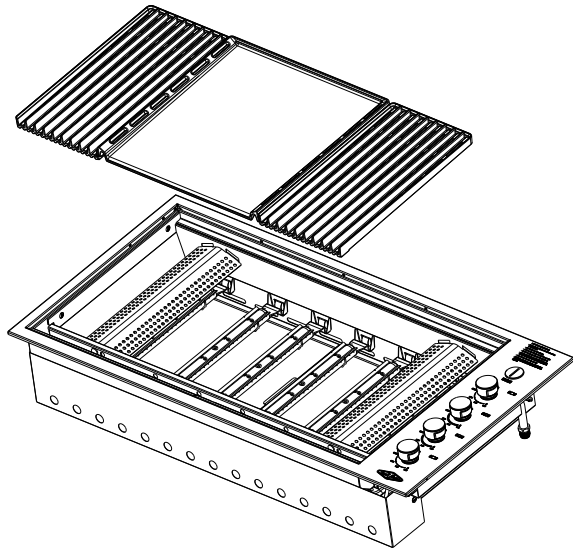

Recommended configuration: Hotplate in centre.

Recommended for roasting and grilling and offer the optimal heat distribution across the cooking surface.

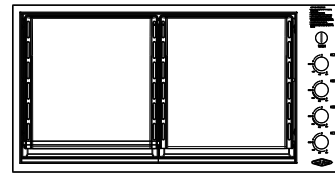

Non-recommended configuration: two Hotplates.

This may cause damage to the appliance as well as excessive temperatures in surrounding surfaces and reduced roasting performance (if roasting hood is fitted).

# OPERATING INSTRUCTIONS

## Control functions

Before lighting the barbecue:

- Check that all hoses and gas fittings are tight.
- Open the slimline lid or the roasting hood.

NOTE: The slimline lid is designed as a cover for weather protection. The lid is not designed to be used as a cooking hood.

- Check all control knobs are in the 'OFF' position.
- Ensure that the cooking surfaces are clean.
- Turn the gas isolation valve 'ON'.

## Lighting instructions

- Do not attempt to light burners with the cooking surfaces covered.
- Read instructions before lighting.
- To light a burner, depress the knob and rotate to 'BOOST'.
- Hold for 3 seconds, release and check the flame.
- If burner did not light, turn knob to the 'OFF' position. Allow gas to disperse, then repeat lighting procedure.

## Manual lighting

- If, in the event of the automatic ignition system not working, the barbecue can be lit manually.
- To light manually, fit a 40mm match to match holder provided. Pass lit match through viewing holes below the front of cooking plates down towards the burner, then rotate the knob to 'BOOST' to ignite. If ignition fails turn the control valve off and allow several minutes for the gas to disperse before attempting to light again.
- Once alight, repeat for other burners as required.

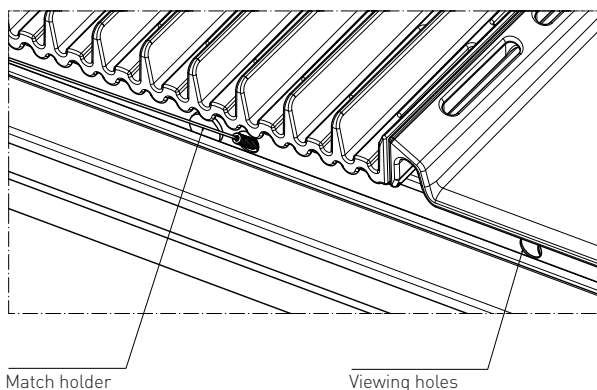

## Preheating

For best cooking results it is recommended to preheat the barbecue prior to cooking.

- This barbecue is fitted with high power burners. In most conditions it will only be necessary to preheat the barbecue for 5 minutes before cooking can commence.
- As with most things, experience will familiarise you with the time required to achieve the desired cooking temperature.
- If the barbecue is fitted with slimline lid, it is advisable to remove the slimline lid in windy conditions.
- If the unit does not operate correctly refer to troubleshooting section on page 20.

## Cooking methods:

### Direct cooking / grilling

- For best cooking results testing has shown that once preheated burners can be reduced to a Medium to Low setting to maintain satisfactory cooking temperatures.
- If burners are left to run too hot there will be excessive smoking during the cooking process and subsequent burning of the food being prepared. This may also result in excessive flaring of the fat being emitted from the food.

### Indirect cooking / roasting

- For barbecue models fitted with a roasting hood, it is recommended that once preheated only use the two outer burners on a low setting to maintain satisfactory cooking temperatures.
- Using more than two burners is not recommended as hood can overheat and may cause damage to the appliance. The temperature gauge indicates the desired range of roasting temperatures.

## To turn the burners off

- When the cooking is complete, rotate the knob fully clockwise so the pointer is positioned at the off position.



To ensure that the user remembers to turn off the gas before closing the lid, a pivoting safety leg has been fitted.

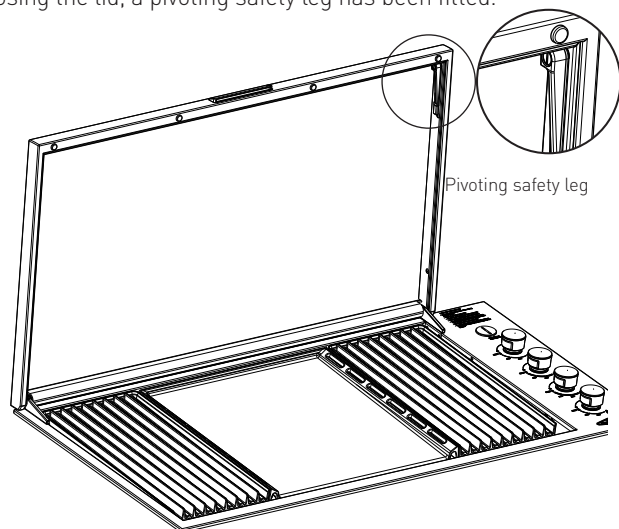

When closing the lid the safety leg will pivot forward and rest against the trim surface to prevent the lid closing. After ensuring the gas has been turned off, to fully close the lid, the leg needs to be rotated backwards.

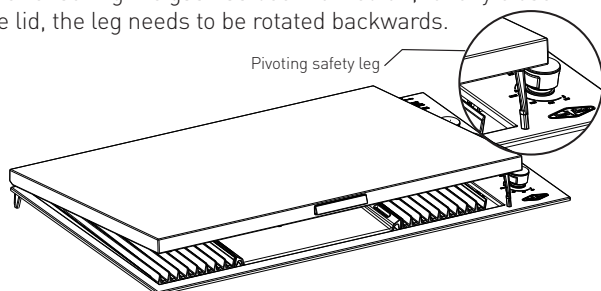

**! WARNING!**

**THE SLIMLINE LID MUST NOT BE CLOSED WHEN THE BURNERS ARE OPERATING.**

**Closing the lid during burner operation can cause discolouration and damage to the lid and barbecue unit. Any damage caused to the unit by closing the lid during the burner operation will not be claimable under your manufacturer's warranty.**

The Electrolux Integrated barbecue has been constructed from select grade stainless steel which, if not cared for, may discolour over time. To keep your barbecue looking its best we recommend that the cooking surfaces are cleaned after every use.

The cleaning and care instructions are essential for the proper functioning and operation of your appliance over time. Failure to adhere to these care instructions may affect your ability to make a claim under the manufacturer's warranty.

**! WARNING!**

**Please ensure that your barbecue is switched off and has cooled down before following the instructions below.**

### Cast Iron plates

The cooking plates and grills have a porcelain enamel coating.

**NOTE:** Many food acids, juices, marinades and sauces contain highly acidic elements that will slowly attack the surface of the cast iron if not removed immediately after cooking.

After use remove all the solid material from the cooking surface using a brass bristled barbecue brush or plastic bristled scourer. Wipe off the remaining grease with paper toweling. Gently wash the surfaces with a cloth or a sponge and a mild detergent and hot water. Dry the components immediately and coat the cooking surface with a light layer of cooking oil. This protects the surface when not in use. Do not clean the cooking surface in a dishwasher.

### Intensive cleaning cycle

Suitable for cast Hotplate and cast grills only!

In instances when the cooking surface becomes heavily soiled and harder to clean, the barbecue can be set-up for an intensive cleaning cycle.

To do this you must have the hood/lid fully open and remove any stainless steel attachments such as the warming racks. Turn all the burners on and set all controls to 'BOOST'. After approximately 30 minutes, this should turn any baked on food or grease to ash. Once the surface has cooled, the residual ash can be wiped clean with a damp cloth.

After cleaning, lightly season the cast MaxiPlate and cast grills with cooking oil.

**! WARNING!**

**The hood or lid must be fully open during the cleaning process.**

**Failure to do so can result in damage to the stainless steel surfaces and to the barbecue unit.**

# CLEANING AND CARE

## Other stainless steel surfaces



**Do not use abrasive or caustic cleaners, scourers or metal scrapers on these stainless steel surfaces as they may permanently scratch and damage your barbecue.**

- Wash all stainless steel components, including the slimline lid, the roasting hood and control knobs with a soft dishcloth using hot soapy water.
- The barbecue interior can be wiped down with a soft cloth in hot soapy water. The rear panel of the interior is removable for easy cleaning.
- Ensure that all surfaces are dried with a clean dry cloth.



**Take extra care (particularly when cleaning on and around the control knobs) to ensure that water and soapy residue do not enter the control panel, where the valves are or into the burners. Care should also be taken not to disturb the spark electrode.**

**A distance of 5mm should be maintained between it and the burners (see diagram below).**

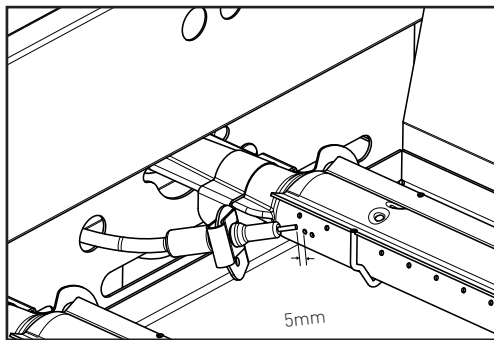

## Cleaning inside the barbecue

The inside of the burner box should be regularly cleaned to prevent any build up of food residue.

To access the burner box remove the cooking plates and flame tamers and rear heat shield panel. The burners can then be removed (refer page 8 "Changing Injectors"). The heat shield panels in the base of the burner box can then be lifted out for cleaning purposes.

Ensure all oil and food particles are removed. After cleaning complete, re-assemble ensuring the burner is correctly located over the injector.

## Cleaning the oil reservoirs

The Integrated barbecue has a unique oil management system which uses channels to drain all oil to the front into easily removed reservoirs and should be cleaned after each use.

- To remove reservoirs, pull upwards from the front of the barbecue and dispose of the contents of the catchment responsibly. Rinse oil reservoirs in warm soapy water. The reservoirs can be placed in the dishwasher if desired.



## Special note on "tea staining"

Sometimes stainless steel surfaces are affected by a brown discolouration called tea staining. This usually occurs in areas which use high heat and can be easily removed using specialised stainless steel cleaners. For best results, we recommend that specialised cleaners be used regularly on all stainless steel components. You will find these cleaners at Electrolux spare parts outlets.



## Special note on stainless steel

The stainless steel panels may distort while in use but will return to normal when cold.

Please note that environmental conditions need to be taken into account with regards to the maintenance required on your product. In particular units installed in humid climates or seaside locations will be more susceptible to surface corrosion/discolouration over time. In these conditions Electrolux strongly recommends cleaning and drying your barbecue after every use and covering it when not in use to minimise exposure to the elements.

# MAINTENANCE

## The ignition system

To change the battery rotate the cover anti-clockwise to release. Lift off the cover to access spring and battery. Lift out the spring and battery. Replace with a new AA battery and replace the cover. Test by depressing the knob and an audible 'clicking' sound should be heard.

NOTE: Ensure that the battery has been placed in the correct orientation.



## Air vents

The mounting enclosure air vents should be checked prior to each use, to ensure they are clear of any obstructions that may affect the free flow of air.

## Stainless steel burners

Burners should be checked and cleaned before each use if required, ensure no residues have been deposited and gas ports are clear. Burner venturi should be clear of any obstruction to ensure correct operation.

This appliance should be checked and serviced by an authorised service person every 2 years to ensure the appliance remains in a safe operating condition. (These services are not covered by warranty). Replacement parts are available from your authorised BeefEater dealer.

SERVICE AND MAINYENANCE SCEDULES	EACH	6 MOM
Check gas supply hose(s) for cracks and leaks	✓	
Check gas regulator for leaks	✓	
Check that all gas fittings are tight	✓	
Inspect and clean burner venturi	✓	
Inspect and clean barbecue burners		✓
Check gas cylinder expiration date		✓
Inspect and clean gas injectors		✓
Check gas control valve on cylinder		✓
Inspect gas control valves		✓
Inspect and proof all internal structure barbecue and trolley		✓

## TROUBLESHOOTING

## ACCESSORIES

PROBLEM	POSSIBLE CAUSE	REMEDY
Barbecue won't light	No gas	Check isolation valve is ON. Gas bottle empty - refill or change gas bottle.
	Ignition system not working	Check battery - should hear a clicking noise when the knob is depressed. Replace battery. Manually light the barbecue.
	Ignition electrode wet or dirty	Gently clean and dry electrode ensuring position is correct.
Flame not staying on when knob is released	Knob not held down long enough for flame safeguard to engage	Repeat lighting procedure and hold knob down for 5 seconds
	Port blockage adjacent to thermocouple	Check the flame is present and the tip of the thermocouple is heated by the flame
Excess smoke being emitted from the cooking area	Gas valve set too high	Turn gas valves down or turn off selected burners.
Smell of gas	Gas leak	Turn off gas at the isolation valves. Check for leaks, tighten joints. If problem persists call Electrolux Service.
		<b>DO NOT ATTEMPT TO LIGHT THE APPLIANCE</b>
Oil not draining into removable reservoirs	Incorrect orientation of plate and grills.	Ensure plate and grills are assembled as shown on page 15.
	Plate and grill not clean	Follow cleaning procedure for cast iron plates as detailed on page 17.
Too hot when roasting	Incorrect burner settings	When roasting only use 2 outer burners on a low setting. Check temperature gauge and adjust accordingly to achieve desired roasting temperature.
Too hot when grilling	Incorrect burner settings	Once preheated, only use a low burner setting. Running "Boost" will quickly achieve temperatures in excess of 400°C and will char food on contact. This should be avoided.

To order any of the following accessories and spare parts, or for more information on any other suitable accessories for this product, please contact the Electrolux Customer Service Centre.

### ACCESSORIES

#### standard inclusions+

gas conversion kit - Gas injectors to convert product to other approved EU gas types.

#### optional extras \*

weatherproof cover

# NOTES



---

---

---

---

---

---

---

---

---

---

---

---

---

---

---

---

---

---

---

---

---

---

---

---

---

---

---

---

---

---





FOR SALES IN EUROPE  
 APPLIANCE: BEEFEATER INTEGRATED BARBECUE

**Should any part fail due to defective workmanship or faulty materials within the specified period from the date of purchase, BeefEater or its distributor will repair or, (at distributors option), replace the defective part free of charge.**

**• LP / Propane Gas Cylinder**

The cylinder manufacturer is responsible for the materials, workmanship and performance of the gas cylinder. Contact your dealer or the cylinder manufacturer in respect of all warranty claims or service.

**• Warranty Administration**

In Australia, warranty is administered by BeefEater Barbecues. In other countries, contact your authorised BeefEater retailer for details of your BeefEater distributor.

- To ensure speedy processing of your warranty service claim, ensure that you record all specific details about your appliance in the space provided. Keep this information handy for future reference.

**Not covered**

Exposure of the barbecue appliance to the elements should be minimised. Once the unit has cooled and is cleaned, store the barbecue under cover. Polyester/ Vinyl barbecue covers are an optional accessory that will ensure years of trouble free operation.

This warranty does not cover the purchaser or any other person for damage, malfunction or loss due to the following:

- Lack of maintenance, abuse, neglect, misuse, accident or improper installation of this appliance.
- Scratches, dents, corrosion or discolouring caused by heat, abrasive or chemical cleaners or chipping on porcelain parts.
- Corrosion or damage caused by exposure to the elements, grease fires, insects, weather or hail. Note: Barbecues must be covered when not in use.
- Cleaning and normal wear and tear. Service calls of this nature are chargeable.
- Rusting of cast iron plates, grills and burners. Note: Rust should be removed by a scrub pad and the surface coated with cooking oil. See owners manual – Caring for cast iron cooking surfaces. Cooktops must be covered when not in use.
- Commercial use of the barbecue.
- Unauthorised repairs during the warranty period
- Removal or re-installation costs.

**Conditions of Warranty**

1. The appliance is delivered to the BeefEater distributor's service department or authorised service agent and freight charges both ways are paid by the owner. No liability is accepted for loss or damage during transit.
2. The appliance is operated and maintained in accordance with the instructions supplied. Repairs or service must be carried out by an authorised person.
3. Installation must conform to the applicable Gas, Electrical and Building standards laid down by the local codes for your country or region.
4. No alterations or repairs have been carried out without obtaining the distributors prior consent. Such repair or any replacement does not extend the warranty period.
5. Proof of purchase together with the warranty card must be provided to verify purchase date and establish the warranty period. Only the original purchaser is covered under this warranty.
6. The warranty period is calculated from the date of purchase only.
7. Where this warranty is inconsistent with any state laws, the statutory rights of the purchaser shall prevail.
8. Parts installed from other manufacturers' products will void this warranty.

**Service assistance**

To assist you when contacting your after sales service contact to arrange a service call please complete the following details and have them ready when you call. You do not need to register your warranty. However, you must retain your receipt or proof of purchase. When claiming warranty for this appliance you must provide a copy of your proof of purchase receipt. No claims for warranty will be accepted without proof of purchase.

**TERMS OF WARRANTY (YEARS)**

<b>Barbecue</b>	
Stainless Steel burner box	25
S/S burners	5
Cast iron cooktops	3
Valves	2
Ignition system	2
All other parts	2
<b>Hood</b>	
Hood	2
Cast alloy parts	2
All other parts	2

For more information on all Beefeater products, or for dimension and installation information, call into your retailer, phone or email our customer care team or visit our website:

## **EUROPE**

BeefEater Europe

PO Box 1238

Cheddar

BS27 9AH

United Kingdom

phone UK: +44 (0) 8455 436001

phone EU: +44 (0) 1934 743362

email: [sales@beefeaterbarbecues.co.uk](mailto:sales@beefeaterbarbecues.co.uk)

web: [www.beefeaterbbq.com](http://www.beefeaterbbq.com)

Beefeater. We are part of the Electrolux Family.  
To add a touch of professional inspiration to  
your home, visit [electrolux.co.uk](http://electrolux.co.uk)