

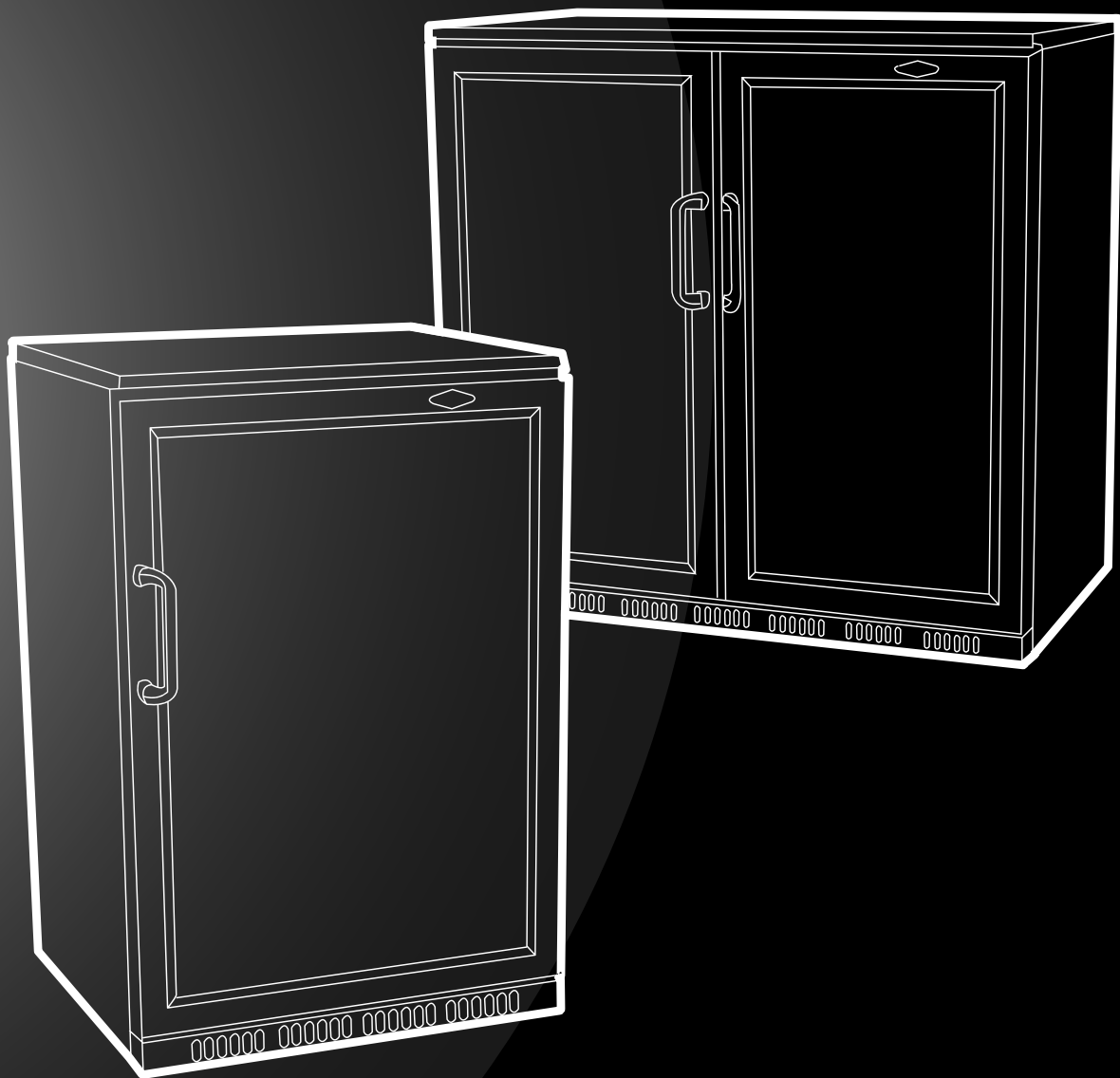

Assembly and
Operating Instructions

GLASS DOOR REFRIGERATOR

BS28131, BS28132, BS28201, BS28202



FOR OUTDOOR USE ONLY

UK & EUROPE



Dear customer,
 Congratulations and thank you for choosing our outdoor display fridge. We are sure you will find it a pleasure to use. Before you use the outdoor display fridge, we recommend that you read through the relevant sections of this manual, which provide a description of your appliance and its functions.

To avoid the risks that are always present when you use an appliance, it is important that the appliance is installed correctly and that you read the safety instructions carefully to avoid misuse and hazards.

We recommend that you keep this instruction booklet for future reference and pass it on to any future owners.

After unpacking the appliance, please check it is not damaged. If in doubt, do not use the appliance but contact your local customer care centre.

This appliance complies with requirements of relevant Australian Standards.

Conditions of use

These important notes apply to your appliance, failure to adhere to these conditions of use may affect your ability to make a claim under the manufacturer's warranty.

- This appliance must be serviced only by a qualified licenced person.
- This product is intended for personal, domestic or household use only, not commercial use.
- This product is intended for outdoor use only.
- This product must be installed, operated and maintained as per the instructions.
- Ventilation holes in the unit must not be obscured by the installation.

Please ensure you read the instruction manual fully before you call for service, or a full service fee could be applicable.

Record model and serial number here:

Model number:

Serial number:.....

PNC:.....

Important safety instructions.....3
 Before using for the first time.....5
 Electrical control6
 Operating the light.....8
 Warranty11

Please read the user manual carefully and store in a handy place for later reference.

The symbols you will see in this booklet have these meanings:



WARNING

This symbol indicates information concerning your personal safety.



CAUTION

This symbol indicates information on how to avoid damaging the appliance.



IMPORTANT

This symbol indicates tips and information about use of the appliance.



ENVIRONMENT

This symbol indicates tips and information about economical and ecological use of the appliance.

IMPORTANT INFORMATION THAT MAY IMPACT YOUR MANUFACTURER'S WARRANTY

Adherence to the directions for use in this manual is extremely important for health and safety. Failure to strictly adhere to the requirements in this manual may result in personal injury, property damage and affect your ability to make a claim under the BeefEater manufacturer's warranty provided with your product. Products must be used, installed and operated in accordance with this manual. You may not be able to claim on the BeefEater manufacturer's warranty in the event that your product fault is due to failure to adhere this manual.

Please read the user manual carefully and store in a handy place for later reference.



IMPORTANT

Important – check for any damages or marks

If you find the barbecue is damaged or marked, you must report it within 7 days if you wish to claim for damage/marks under the manufacturer's warranty. This does not affect your statutory rights.



ENVIRONMENT

Information on disposal for users

- Most of the packing materials are recyclable. Please dispose of those materials through your local recycling depot or by placing them in appropriate collection containers.
- If you wish to discard this product, please contact your local authorities and ask for the correct method of disposal.



WARNING

This appliance must be serviced only by a qualified licensed person.

Improper installation, adjustment, alteration or maintenance can cause injury or property damage and may affect your ability to claim under the manufacturer's warranty.

Please contact your nearest BeefEater Service Department for additional information or assistance for an approved installer.

Note to the installer

This manual must remain with the owner for future reference.

This outdoor display fridge has been designed to be built-in in a cabinet or similar "Outdoor Kitchen" arrangement.

This appliance is intended to be used in household and similar applications only.

Before starting the installation, consideration should be given to how the installation is to be carried out, ensuring

- Adequate space and clearances.
- Preventing exposure to the elements.
- Preventing any exposure to direct sun light.
- Availability of earthed power.
- The mechanical strength of supporting structures.

The installation work must be undertaken by a qualified and competent person in conformity to the rules concerning connection of electric power and wiring rules.

The manufacturer does not accept any liability for any damage or injury caused by improper installation. Before connecting to the mains supply ensure that the mains voltage corresponds with the voltage on the outdoor display fridge's rating label.

Make sure the electric plant of your house is correctly earthed.

When installed, the outdoor display fridge must be positioned to ensure no moisture ingress into the appliance or the appliance compartment.

- Before carrying out any kind of maintenance or cleaning, disconnect the outdoor display fridge from the mains supply.
- The appliance must not be operated or left out in the weather. Do not expose the outdoor display fridge to rain or wet conditions.
- This appliance is not intended (including children) with reduced physical, sensory or mental capabilities, or lack of experience and knowledge, unless they have been given supervision or instruction concerning use of the appliance by a person responsible for their safety.
- Children should be supervised to ensure that they do not play with the appliance.
- If the supply cord is damaged, it must be replaced by the manufacturer, its service agent or similarly qualified persons in order to avoid a hazard.
- There shall be adequate ventilation of the area when the outdoor display fridge is used, and vents provided must be kept clear, clean and open.
- There is a fire risk if cleaning is not carried out in accordance with the instructions, or if damage occurs to cooling system.
- Always ensure the outdoor display fridge is kept at the correct settings for the required operation of the appliance.
- Do not use cooking utensils to handle things inside, or clean the interior of the outdoor display fridge, as damage to liners may result.
- During use rear of appliance becomes hot. Care should be taken to avoid touching elements at rear of the outdoor display fridge.
- Children should never be allowed to sit or stand on any part of the appliance.
- Use this appliance only for its intended use.
- This appliance is intended for household use only. It is designed to be used in sheltered areas only and must not be exposed to the elements.
- Do not use electrical appliances inside the food storage compartments of the appliance, unless they are of the type recommended.



IMPORTANT

The outdoor display fridge must never operate in direct sunlight. The outdoor display fridge will not operate to specifications if sunlight penetrates the glass doors. Prolonged exposure to direct sunlight inside the outdoor display fridge will result in increased temperature, excessive energy consumption, and even premature component failure, and will not be covered by warranty.

i IMPORTANT

Before switching your BeefEater outdoor display fridge on for the first time, read the information in this user manual carefully. This manual contains important information relating to the assembly, operation and maintenance of the appliance.

Please keep this booklet in a safe place for future reference. If you ever sell your BeefEater outdoor display fridge, hand this user manual to the new owner.

The manufacture does not accept responsibility for any damages that may arise due to non-observation of these instructions. The user is liable for any material damage or bodily injury (product liability) cause by using the refrigerator carelessly or failing to follow instructions.

- Do not use damaged appliance. If you are in any doubt, consult a suitably qualified technician.
- Connection and installation of your BeefEater outdoor display fridge are to be carried out in strict compliance with the instructions in this manual.
- For safety, the appliance must be properly earthed in accordance with specifications
- Do not damage any parts of the appliance which carry refrigerant by piercing, perforating, crushing, twisting or scraping. If the refrigerant comes into contact with the eyes, it may cause serious eye injury.
- Always remember to unplug the appliance before cleaning. Never unplug your appliance by pulling on the power cable. Always grip plug firmly and pull straight out from the socket. Always check that the plug and cable are undamaged.
- All repairs must be carried out by a qualified technician. Inadequate repairs may be dangerous. Never try to repair the outdoor display fridge yourself.
- Should the cover of the interior light or fan fall off or break, switch the outdoor display fridge off immediately and replace the cover.
- Ensure your chosen location has a flat and stable surface. The unit may be leveled by turning either or both of the adjustable feet in the front corners. Check the unit is level using a spirit level.
- Do not obstruct or cover the ventilation aperture.
- Make sure there is a suitable power Outlet (240 volts, 10 amps outlet) with proper grounding to power the refrigerator.

Disposal of Old Appliances

Be sure to make any locks unusable, remove any door(s) and discard separately.

! WARNING

Chemical hazard: do not allow children to play with the old appliance.

Contact your local authority for disposal procedures.

Before disposing of an old appliance, make sure it is switched off and safe. Unplug the appliance and break any locks in order to avoid becoming trapped.

NOTE: refrigeration system contains gas and refrigerants which require specialised waste disposal. Some vulnerable materials in a refrigerator can be recycled. Contact your local waste disposal depot for proper disposal of an old appliance and contact your local authority or dealer if you have any questions.

Please ensure the cooling systems and tubes of your refrigerator are not damaged prior to disposal.

You can contribute to environmental awareness by insisting on an appropriate non-polluting method of disposal.

Disposal of Packaging

Do not allow children to play with the packaging, and dispose of plastic bags safely.

The cardboard may be broken or cut into smaller pieces and recycled. Any wrapping cover is made of polyethylene. The polyethylene pads and padding contain no fluorochloric hydrocarbons, and as such are most suitable for adequate recycling.

! WARNING

R600a refrigerant warning

This appliance contains flammable R600a refrigerant. Avoid safety hazards by carefully installing, handling, servicing and disposing of this appliance.

- Ensure that the tubing of the refrigerant circuit is not damaged during transportation and installation.
- Leaking refrigerant may cause eye injuries or ignite.
- The room for installing appliance must be at least 1m³ per 8g of refrigerant. The amount of refrigerant in the appliance can be found on the rating plate inside the appliance.
- If you are unsure of the refrigerant check the rating plate inside the refrigerator compartment.
- It is a hazardous for everyone other than an Authorised Service Person to service this appliance. In
- Keep ventilation openings in the appliance enclosure or in the built-in structure, clear of obstruction.
- Do not use mechanical devices or other means to accelerate the defrosting process, other than those recommended by the manufacturer.

Do not position this appliance with its rear panel directly against a wall. For good circulation and operating efficiency, the ventilation grilles must never be blocked.

Remove all packaging and place the BeefEater outdoor display fridge on a stable, secure flat surface. Position the BeefEater outdoor display fridge away from heat sources, where the unit is well-ventilated and protected from moisture, or extremes of heat or cold. The outdoor display fridge may not function properly if the ambient temperature rises above 40° for prolonged periods of time.

When installed in a BeefEater Outdoor Kitchen, ensure the vents behind the outdoor display fridge are clear, clean and not obstructed from the other side, such that air circulation is enabled.

Do not use an extension lead. If the mains cable will not reach the nearest socket, either rearrange your installation layout or ask a qualified electrician to fit a new socket.

If power is cut off, wait for at least 5 mins before plugging the unit in again to avoid damaging the compressor.

Do not place combustible, explosive or volatile articles, corrosive acid or alkali, or liquid in glass containers into the BeefEater outdoor display fridge. Always exercise caution if adjusting the temperature.

i IMPORTANT

Allow the outdoor display fridge to stand still and upright for 8 hours before plugging it into the power.

Preparation

Position the Shelf-Supports inside the racks on the sides as illustrated below, at your required level, and then place the shelves firmly on the supports.

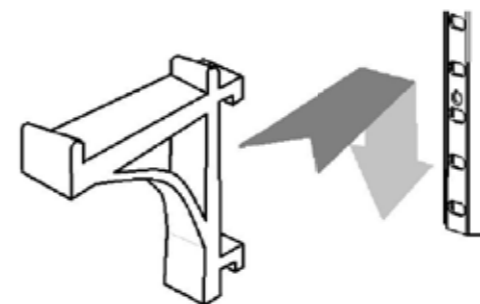

The maximum load for a shelf is 40kg.

NOTE: check that the refrigerator is functioning correctly before installing shelves and filling it.

Cleaning

1. Unplug your BeefEater outdoor display fridge from power source and remove any items from inside. It is best to place these temporarily in another refrigerator.
2. Wash the inner compartment with warm water and neutral mild detergent. DO NOT allow the control panel, cables or plug to get wet.

i IMPORTANT

NEVER use corrosive detergents, wire blasters, or abrasive scourers to clean your BeefEater outdoor display fridge.

NEVER use metal or sharp implements to scrape any part of the fridge.

3. Dry all surface thoroughly.
4. To ensure trouble-free operation the condenser should be cleaned every three months where appropriate using a vacuum hose. The condenser is located behind lower grill of the cabinet. In exceptionally dusty

i IMPORTANT

It is recommended that areas around the condenser are cleaned more often.

5. Use mild soapy water to clean the gasket and seals around the door.
6. The external surfaces of the fridge can be cleaned with warm water and mild detergent, or with a suitable Stainless-Steel cleaning material.

The electric controller is located outside the unit on the bottom, right-hand side front plinth. It looks like this:

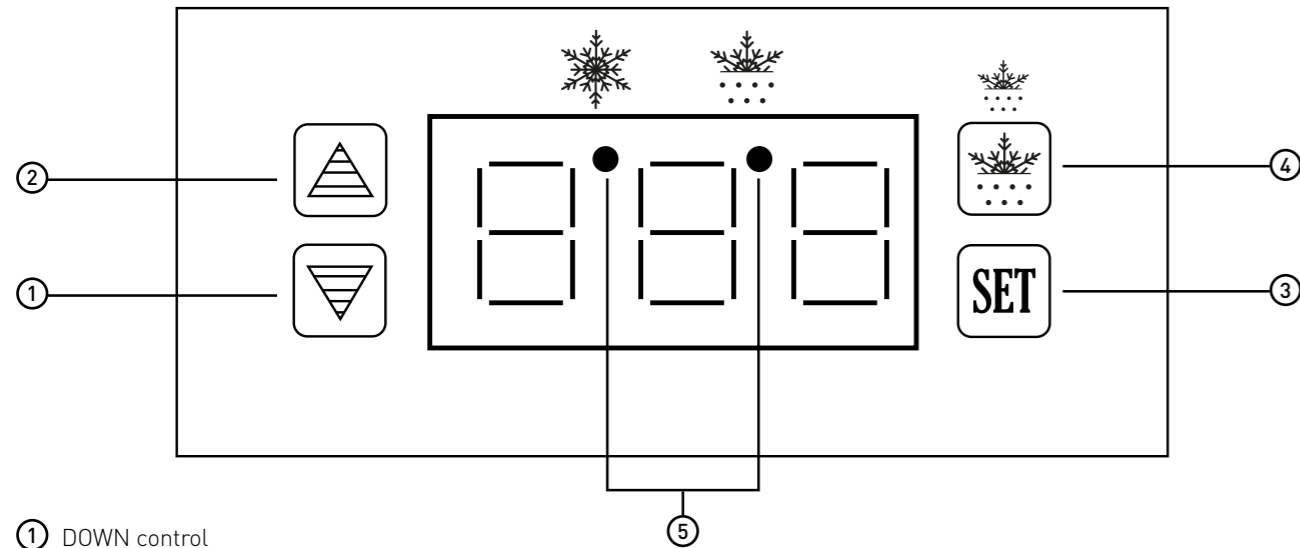

- ① DOWN control
- ② UP control
- ③ SET control
- ④ DEFROST control
- ⑤ Indicator lights

During normal operation the controller display 8'8'8 will show the temperature inside the refrigerator.

A small indicator light will illuminate under the 'cooling' symbol to confirm the fridge is in its normal cooling mode, and compressor is running.

Operation of the controller

To set the desired temperature of the fridge

- Press the **SET** button once. A 'beep' will sound, and the display will start to flash.
- Use buttons to set to the desired temperature.
- Press **SET** again to complete the operation, or just leave it for 5-10 seconds, and the display will revert back to showing internal temperature, while new settings saved.

NOTE: The fridge is built to automatically defrost and prevent any ice forming on the Evaporator.

It will automatically run a 'Defrost cycle' for 20min once every 8 hours.

When in a 'Defrost' cycle, the indicator light will illuminate under the 'Defrost' symbol .

To manually activate 'Defrost' cycle

- Press the button and hold it. a 'beep' will sound as soon as pressed.
- Hold button pressed for 10 – 20 seconds, until a second 'beep' can be heard.
- The indicator light will now illuminate under the 'defrost' symbol and the fridge is into 'defrost' cycle.
- 'Defrost' will run for 20mins, and then automatically revert to normal operation.

To manually change back to normal operating mode from the 'defrost' mode

- Press the button again, a 'beep' will sound.
- Hold button pressed for 10 – 20 seconds, until a second 'beep' is heard.
- Both indicator lights under the 'defrost' symbol and under the 'cooling' symbol will now flash while the fridge is gearing up to switch back to normal operation.
- After 5 – 20 minutes, only the indicator light will illuminate under the 'cooling' symbol to confirm the fridge is back in its normal cooling mode.

i IMPORTANT

- The fridge will go through a normal periodical defrosting cycle, and a manual defrosting operation is only require in most extreme cases. It is better to avoid if not necessary.
- While in the 'defrost' mode, the fridge cooling power is reduced working. The automatic cycles ensure the defrosting is done in the most efficient manner, a when required. It is not recommended to leave the fridge in the manually set defrost mode for prolonged periods of time.

NOTE: The controller allows you to choose a desired operating temperature of between -2°C and 8°C. BeefEater do not recommend to operate the fridge on settings of below 4°C, as such setting will cause content of the fridge to freeze, and will result in unnecessary strain on the cooling systems, and undue high energy consumption.

It is advisable to keep the cover over the controller closed when not being accessed, so no unintended operation or damage will occur.

In normal operation the controller turns the compressor off at the set temperature and back on after the temperature had risen a few degrees. As such, the reading in the controller is always a couple of degrees above set-point and that is perfectly okay.

When the temperature was reached and the compressor is in its 'off' cycle, no indicator light will illuminate.



Electrolux Warranty

FOR SALES IN UK & Europe
APPLIANCE: BEEFEATER REFRIGERATORS

This document sets out the terms and conditions of the product warranties for BeefEater Appliances. It is an important document. Please keep it with your proof of purchase documents in a safe place for future reference should there be a manufacturing defect in your Appliance. This warranty is in addition to other rights you may have under Consumer Law.

1. In this warranty:

- (a) 'Appliance' means any Electrolux product purchased by you and accompanied by this document;
- (b) 'BeefEater' is the brand distributed by M Richards Ltd. (t/a BeefEater Europe, PO Box 1238, Cheddar, BS27 9AH, UK
- (c) 'Warranty Period' means the period specified in clause 3 of this warranty;
- (d) 'you' means the purchaser of the Appliance not having purchased the Appliance for re-sale, and 'your' has a corresponding meaning.

2. Application: This warranty only applies to new Appliances, purchased and used in UK & Europe and is in addition to (and does not exclude, restrict, or modify in any way) other rights and remedies under a law to which the Appliances or services relate, including any non-excludable statutory guarantees in UK & Europe.

3. Warranty Period: Subject to these terms and conditions, this warranty continues for a period of 24 months, following the date of original purchase of the Appliance. Specific components are warranted against manufacturing defects in UK & Europe for the periods listed below;

- Compressor – Further 3 years parts only,
- External Condenser – Further 3 years parts only
- Evaporator – Further 3 years parts only
- Drier – Further 3 years parts only

4. Repair or replace warranty: During the Warranty Period, M Richards Ltd or its authorised distributor will, at no extra charge if your Appliance is readily accessible for service, without special equipment and subject to these terms and conditions, repair or replace any parts which it considers to be defective. M Richards Ltd or its authorised distributor may, in its absolute discretion, choose whether the remedy offered for a valid warranty claim is repair or replacement. M Richards Ltd or its authorised distributor may use refurbished parts to repair your Appliance. You agree that any replaced Appliances or parts become the property of M Richards Ltd or its authorised distributor.

5. Travel and transportation costs: Subject to clause 7, M Richards Ltd or its authorised distributor will bear the reasonable cost of transportation, travel and delivery of the Appliance to and from M Richards Ltd or its authorised distributor. Travel and transportation will be arranged by M Richards Ltd or its authorised distributor as part of any valid warranty claim.

6. Proof of purchase is required before you can make a claim under this warranty.

7. Exclusions: You may not make a claim under this warranty unless the defect claimed is due to faulty or defective parts or workmanship. This warranty does not cover:

- (a) light globes, batteries, filters or similar perishable parts;
- (b) parts and Appliances not supplied by M Richards Ltd or its authorised distributor;
- (c) cosmetic damage which does not affect the operation of the Appliance;
- (d) damage to the Appliance caused by:
 - (i) negligence or accident;
 - (ii) misuse or abuse, including failure to properly maintain or service;
 - (iii) improper, negligent or faulty servicing or repair works done by anyone other than an M Richards Ltd or its authorised distributor authorised repairer;
 - (iv) normal wear and tear;
 - (v) power surges, electrical storm damage or incorrect power supply;
 - (vi) incomplete or improper installation;
 - (vii) incorrect, improper or inappropriate operation;
 - (viii) insect or vermin infestation;
 - (ix) failure to comply with any additional instructions supplied with the Appliance;

In addition, M Richards Ltd or its authorised distributor is not liable under this warranty if:

- (a) the Appliance has been, or M Richards Ltd or its authorised distributor reasonably believes that the the Appliance was intended, including where the Appliance has been used for any non-domestic purpose;
- (b) the Appliance is modified without authority from M Richards Ltd or its authorised distributor in writing;
- (c) the Appliance's serial number or warranty seal has been removed or defaced.

8. How to claim under this warranty: To enquire about claiming under this warranty, please follow these steps:

- (a) carefully check the operating instructions, user manual and the terms of this warranty;
- (b) have the model and serial number of the Appliance available;
- (c) have the proof of purchase (e.g. an invoice) available;
- (d) telephone the numbers shown below.

9. Confidentiality: You accept that if you make a warranty claim, Electrolux and its agents including ASC may exchange information in relation to you to enable Electrolux to meet its obligations under this warranty.

Important Notice

Before calling for service, please ensure that the steps listed in clause 8 above have been followed.

<p>FOR SERVICE or to find the address of your nearest authorised service centre in Australia Please call +44 (0)1934 743322</p>	<p>M Richards Ltd. (t/a BeefEater Europe) PO Box 1238, Cheddar, BS27 9AH, UK www.beefeaterbbqeuropa.co.uk</p>	<p>FOR SPARE PARTS or to find the address of your nearest spare parts centre in Australia Please call +44 (0)1934 743322</p>
<p>FOR SERVICE or to find</p>		

BFridgeFreezer_Warr_May17

For more information on all BeefEater products, or for dimension and installation information, call into your retailer, phone or email our customer care team or visit our website:

BeefEater Europe
PO Box 1238
Cheddar
BS27 9AH

Tel: +44 (0)1934 743322
Email: sales@beefeater europe.co.uk
web: www.beefeaterbbq europe.co.uk